

Revision 3.01

November 1, 2009

**CRASH AND SAFETY TESTING STANDARD
FOR PARATRANSIT BUSES
ACQUIRED BY THE STATE OF FLORIDA**

FULL DOCUMENT

Approved by the Transit Office
Florida Department of Transportation

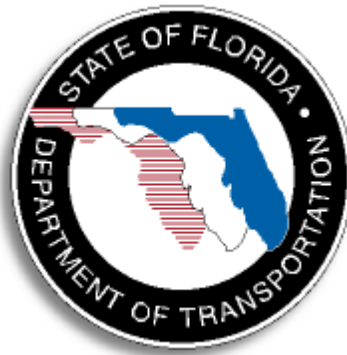

Prepared by:

Crashworthiness and Impact Analysis Laboratory
FAMU-FSU College of Engineering
2525 Pottsdamer Street
Tallahassee, FL 32310-6046
<http://www.eng.fsu.edu/~wekezer>



CRASH AND SAFETY TESTING STANDARD
FOR PARATRANSIT BUSES ACQUIRED BY THE STATE OF FLORIDA

CONTENTS

		<u>Page</u>
1.	Scope	2
2.	Terms and definitions	2
3.	Approval	4
	3.1. Approval methods	4
	3.2. Partial validation requirements	4
	3.3. Impact scenarios	4
	3.4. Full-scale crash tests	5
4.	Crashworthiness assessment through full-scale experiments.....	5
	4.1. Requirements	5
5.	Finite element model development	5
	5.1. Input data	5
	5.2. FE model requirements	6
6.	Verification and validation of FE models	6
	6.1. Verification and validation	6
	6.2. New vehicle types and updated models	6
	6.3. Material characterization tests for major structural parts of the body	6
	6.4. Quasi-static connection tests	7
	6.5. Impact hammer test of a bus wall panel	7
	6.6. Verification of center of gravity, mass and wheel reactions	7
	6.7. Verification of energy	7
7.	Crashworthiness assessment through computer simulations	7
	7.1. Computational mechanics methodology	7
	7.2. Side impact simulation	8
	7.3. Roll-over simulation	8
8.	Disclaimer	8

APPENDICES

<u>Appendix 1-</u>	Residual space	10
<u>Appendix 2-</u>	Material testing of major structural parts of the bus body	12
<u>Appendix 3-</u>	Quasi-static tests of roof-to-wall and wall-to-floor connections.....	13
<u>Appendix 4-</u>	Impact hammer test of a bus side wall panel.....	15
<u>Appendix 5-</u>	Center of gravity of the vehicle.....	18
<u>Appendix 6-</u>	Side impact test	22
<u>Appendix 7-</u>	Roll-over test	23
<u>Appendix 8-</u>	Pre-approval	24

REFERENCES		25
------------------	--	----

1. SCOPE

This Standard applies to single-deck vehicles designed and constructed for more than 8 but less than 22 passengers, whether seated or standing, in addition to the driver and crew. It describes the testing procedures required to assess crashworthiness and safety of paratransit buses in the State of Florida. They are extracted from, and are consistent with all current bus safety standards as required by the U.S., U.N., and E.U. regulations. Either full scale experimental crash tests or computational mechanics finite element methods (FE) shall be used for this assessment. Full scale crash tests include a side impact test and a rollover test. Satisfactory performance of the paratransit buses during actual or simulated side impact and rollover tests is required for their approval. Several laboratory tests are required for validation of the FE models for simulation-based approvals. An uncompromised residual space concept is adopted in this standard as a pass/fail criterion.

2. TERMS AND DEFINITIONS

For the purposes of this Standard, the following units and definitions are used [1]:

- 2.1. Units. SI and U.S. Customary unit systems can be used for experimental tests and in situ measurements. Results can be presented in SI and U.S. Customary. The Finite Element calculations shall be carried using one consistent SI system with mm, s, t (tone) as basic units. The units for FE calculations are provided in Table 2.1.1.

Table 2.1.1. The units for FE calculation

Dimensions and linear distances	millimeters (mm)
Mass	tone (t)
Force (and weight)	Newtons (N)
Stress	Mega Pascal (MPa)
Energy	milli Joules (mJ)
Gravitational constant	9,810 (mm/s ²)

- 2.2. "Vehicle" means a bus or coach designed and equipped for transportation of passengers. The vehicle is an individual representative of a vehicle type.
- 2.3. "Vehicle type" means a category of vehicles produced with the same design technical specification, main dimensions and structural arrangement. The vehicle type shall be defined by the vehicle manufacturer.
- 2.4. "Family of vehicle types" means those vehicle types, proposed in future as well as currently existing, which are covered by the approval of the worst case, in accordance with this Standard.
- 2.5. "Worst case" means the vehicle type, among a group of vehicle types, least likely to withstand the requirements of this Standard with respect to the strength of the superstructure.
- 2.6. "Approval of a vehicle type" means an official process in which the vehicle type is checked and tested to prove that it meets all the requirements specified in this Standard.

- 2.7. "Passenger compartment" means the space intended for passengers' use, excluding any space occupied by additional fixed equipment such as wheelchair lifts.
- 2.8. "Driver's compartment" means the space intended for the driver's exclusive use and containing the driver's seat, the steering wheel, controls, instruments and other devices necessary for driving the vehicle.
- 2.9. "Occupant restraint" means any device which connects a passenger, a driver or a crew member to his/her seat.
- 2.10. "Residual space" means a space to be preserved in the passengers', crew and driver's compartment(s) to provide safe environment for the passengers, the driver and the crew in case of an accident.
- 2.11. "Unloaded curb mass" (M_k) means the mass of the vehicle in running order, unoccupied and unloaded but with the addition of 75 kg for the mass of the driver, the mass of fuel corresponding to 90 percent of the capacity of the fuel tank specified by the manufacturer, and the mass of coolant, lubricant, tools and spare wheel, if any.
- 2.12. "Reference energy" (E_R) means the potential energy of the vehicle type to be approved, measured from the starting, unstable position CG' to the CG" position when the roof-to-wall edge of the bus touches the concrete bottom of the ditch (Figure A7.1).
- 2.13. "Rollover test on a complete vehicle" means a test on a complete, full-scale vehicle to prove the required strength of the superstructure.
- 2.14. "Tilting platform" means a rigid stand which can be rotated around a horizontal axis in order to perform a rollover test on a complete vehicle.
- 2.15. "Body work" means a complete structure of the vehicle in running order, including all structural elements which form the passenger compartment, driver's compartment, baggage compartment and spaces for the mechanical units and components.
- 2.16. "Superstructure" means the load-bearing components of the bodywork as defined by the manufacturer, containing those coherent parts and elements which contribute to the strength and energy absorbing capability of the bodywork, and which preserve the residual space in the rollover test.
- 2.17. "Energy balance" means checking the principle of energy conservation during the standard side impact or the rollover test. The total potential energy of the vehicle is transformed through its kinetic energy into other forms of energy.
- 2.18. "Plastic zone" (PZ) means a special, geometrically limited part of the superstructure produced by dynamic impact forces. Plastic zones are characterized by:
- large scale, concentrated plastic deformations,
 - significant distortion of the original shape (cross section, length, or other geometry),
 - loss of stability resulting from local buckling, and
 - kinetic energy transformed into internal energy.

- 2.19. "Cantrail" means the longitudinal structural part of the bodywork above the side windows including the curved transition to the roof structures. The cantrail hits the ground first during the rollover test.
- 2.20. Finite Element (FE) analysis means non-linear, explicit, computational mechanics study used to assess crashworthiness of the bus and to predict its dynamic, structural response during accidents.
- 2.21. Side impact test means an experimental collision of a SUV or a pickup truck crashing into the driver side of a paratransit bus. The impacted bus shall be stationary at the time of the impact. The test setup is described by such parameters as velocity of the impacting vehicle (SUV), its mass, dimensions of its frontal bumper, an impact angle, and a location of the impacted zone.
- 2.22. Crashworthiness means the bus ability to provide passive safety for the passengers through dissipation of the vehicle kinetic energy during crash accidents. Crashworthiness is achieved through a balanced design with some elements which promote the development of the plastic zones for efficient energy transfer, and with other structural elements which help to preserve the passenger residual space.

3. APPROVAL

- 3.1. Approval methods. Crashworthiness and safety of the paratransit bus shall be assessed by either:
- Experimental, full-scale crash tests, or
 - Numerical analysis using a FE method.
- Both methods are considered equivalent and either one may be selected by the bus manufacturer for the bus approval, as shown in Figure 1. The paratransit bus is considered to be crashworthy and safe if its residual space (as defined in Appendix 1) is neither compromised through intrusion (Section 5.3.1) nor by projection (Section 5.3.2).
- 3.2. Partial validation requirements. Numerical analysis using a FE method requires a reliable and validated FE model. A model validation process, as shown in Figure 1, shall be based on the following laboratory tests:
- Material characterization tests of major structural parts of the body bus (Appendix 2),
 - Quasi-static tests of roof-to-wall and wall-to-floor connections (Appendix 3),
 - Impact hammer test of a bus side wall panel (Appendix 4), and
 - Center of gravity test of the vehicle (Appendix 5).
- 3.3. Impact scenarios. The validated FE model shall be used to assess crashworthiness and safety of the bus through:
- Side impact test (Appendix 6), and
 - Roll over test (Appendix 7).

Successful performance of both tests is required for the approval of the paratransit bus.

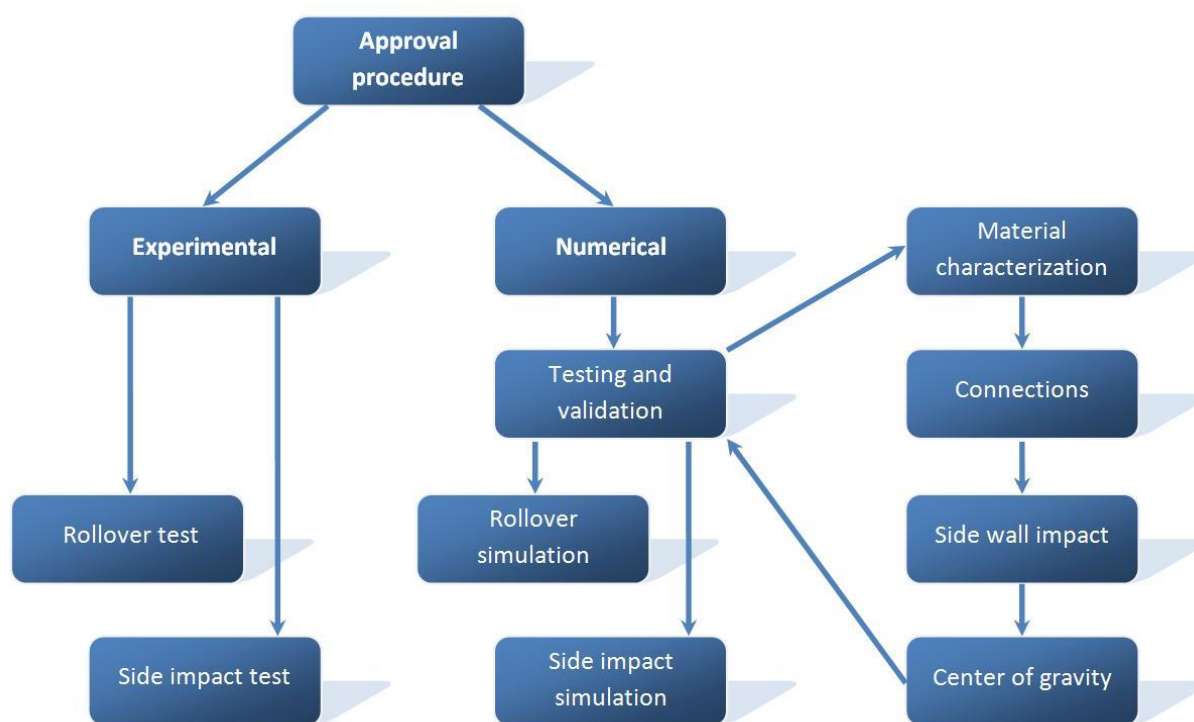

Figure 1. Approval methods for paratransit buses.

3.4. Full-scale crash tests. The experimental full-scale crash test becomes mandatory if the paratransit bus fails either of the computational analysis tests, as listed in Section 3.2.

4. CRASHWORTHINESS ASSESSMENT THROUGH FULL-SCALE EXPERIMENTS

4.1. Requirements. Two full scale tests shall be performed under this option: a rollover test and a side impact tests. Requirements for both tests are included in Appendices 6 and 7.

5. FINITE ELEMENT MODEL DEVELOPMENT

5.1. Input data. All data and information which are needed to evaluate the worst case criteria in a group of vehicle types are required. The following AutoCAD files or their hard copies shall be provided by the manufacturer:

- General layout drawings of the vehicle, its bodywork and its interior arrangement with the main dimensions. Seats shall be clearly marked and their positions in the vehicle shall be accurately dimensioned.
- Drawings and detailed description of the superstructure of the vehicle type or group of vehicle types.
- Thicknesses of the structural components.
- Material identification, its properties, and steel grades.

- If requested, the manufacturer shall answer questions and allow for visual checking of details regarding connections between body structure elements and the methods of construction.
 - The unloaded curb mass of the vehicle, and the associated axle loads.
- 5.2. FE model requirements. The FE model shall be capable of describing a real physical behavior of the actual vehicle subjected to the loadings and conditions present during the tests. The FE model shall be developed based on assumptions which shall produce conservative results. The model shall be developed within the following guidelines:
- 5.2.1. The tests required shall be carried out on the actual vehicle structural elements to prove the validity of the mathematical model and to verify the assumptions made in the model.
 - 5.2.2. The total mass and the center of gravity position used in the FE model shall be equal to those of the vehicle to be approved. A discrepancy of up to $\pm 2\%$ in each is allowed.
 - 5.2.3. The mass distribution in the FE model shall correspond to the vehicle to be approved. Moments of inertia used in the FE model shall be calculated based on this mass distribution.
 - 5.2.4. The F.E. program may start at the moment just prior to the first contact with the bottom of the ditch with the appropriate initial conditions.
 - 5.2.5. The F.E. program shall run until the maximum deformation of the bus is reached.
 - 5.2.6. The F.E. program shall produce a stable solution, in which the result is neither dependent on the incremental time step nor on the F.E. grid density of the model.
 - 5.2.7. The coefficient of friction used at the ground contact shall be carefully selected to produce conservative results. Physical tests shall be considered if appropriate.
 - 5.2.8. All possible physical contacts between parts of the vehicle shall be identified and accounted for in the FE model.

6. VERIFICATION AND VALIDATION OF F.E. MODELS

- 6.1. Verification and validation. Verification is a qualitative process of confirming that a computer code correctly implements the algorithms that were intended. Validation is a quantitative process of confirming that computer simulations adequately represent physical phenomena measured through laboratory or full-scale testing programs.
- 6.2. New vehicle types and updated models. One full-scale rollover test and one full scale rollover test shall be required for a FE model validation of a completely new vehicle type. Due to a high cost of full-scale bus tests, partial FE model validations shall be used when minor structural modifications are introduced in new bus models, as described in Sections 5.3. through 5.6.
- 6.3. Material characterization tests for major structural parts of the body. The main goal of the material testing is to identify actual material properties of the major structural components. Appendix 2 provides guidelines for coupon testing. Material properties acquired from

these tests shall be used in all subsequent elements of the numerical approval process, as described in Sections 5.4 through 5.6.

- 6.4. Quasi-static connection tests. Two vulnerable connections of each bus: roof-to-wall, and wall-to-floor shall be tested for its FE model validation. Each connection shall include all original structural elements, with the bus skin, but without any additional reinforcements, which are not present in the actual bus. Crashworthiness of these structural connections is considered critical during roll-over and side impact accidents. Both quasi-static tests shall be performed according to guidelines presented in Appendix 3. Experimental data shall be used for FE model validation for both connections.
- 6.5. Impact hammer test of a bus wall panel. Vehicle accidents result in significant dynamic loading applied to the bus structure. Energy transfer: from kinetic into internal, and between impacting and impacted vehicles, take place in short time intervals (such as 0.1 second). Dynamic material behavior is dependent on the strain rates and is usually different from its static behavior. Therefore, at least one dynamic test on a side wall panel of the bus shall be performed to validate the F.E. bus model. Appendix 4 describes details of the impact hammer test of a panel cut of the body side wall. Comparison of the experimental results with the computer simulations of the pendulum test shall be used for F.E. model validation.
- 6.6. Verification of center of gravity, mass, and wheel reactions. Mass distribution of the FE model must be compared with actual values from the manufacturer's specification, or from in situ measurements to partially validate the FE model. The comparison shall include the position of the center of gravity (CG), the unloaded curb mass, and the wheel reactions. The testing of the CG location for an actual vehicle shall be based on the procedure described in Appendix 5.
- 6.7. Verification of energy. The FE computer program shall be able to provide calculations of energy components for the energy balance at every incremental time step. The energy balance is a major criterion used for verification of computational mechanics studies. The total energy shall remain constant with kinetic energy transferred into internal energy. Non-physical energy components introduced through FE modeling (for example, "hourglass" and internal damping) shall not exceed 5 percent of the total energy at any time. Kinetic energy shall be verified through classical hand calculations based on the trajectory of the CG of the FE model. An additional CG node, rigidly connected to the floor, shall provide this trajectory data as a direct output.

7. CRASHWORTHINESS ASSESSMENT THROUGH COMPUTER SIMULATIONS

- 7.1. Computational mechanics methodology. An approval of a new vehicle type with regard to the strength of its superstructure shall be made through a validated FE analysis based on the information data and test material acquired from laboratory testing and provided by the vehicle manufacturer. A description of the computational mechanics method which has been utilized, precise identification of the analysis software, including its producer, its commercial name, and the version shall be provided in the final report. The final report shall also include a list of the material models and the input data utilized. FE simulations shall include all numerical tests, as described in Appendices 3 through 7. The final approval of the bus type will be made based on the results of these tests. Both: rollover

and side impact full-scale tests on the complete vehicle shall be considered if the simulation results are not satisfactory.

- 7.2. Side impact simulation. A side impact is one of the critical performance tests, which shall be implemented either as a full-scale crash test, or through computational mechanics analysis. The impacted paratransit bus shall be stationary, while the impacting vehicle shall approach its target with a velocity of 30 mph at a 90° angle. Details of the side impact tests are provided in Appendix 6.
 - 7.2.1. Impacting vehicle. Ford Explorer, Chevrolet S10 pickup, and Chevrolet C2500 pickup trucks shall be used as impacting vehicles. If an alternative vehicle is used, it shall be selected within the similar mass, bumper height, and location of CG as the primary vehicles specified in this Section.
 - 7.2.2. Impact point. The bus shall be impacted between the front and the rear axles, on the street (driver's) side. The closest, right end of the impacting bumper shall be located from the rear bus wheel at a distance of $d = 100$ mm (Figure A6.1.).
 - 7.2.3. Residual space. The bus shall pass the test if the passenger residual space, as defined in Appendix 1, is not compromised as a result of the simulated side impact.
- 7.3. Roll-over simulation. A computational mechanics analysis shall be carried out according to the test procedure described in Appendix 7. The approval is based on the concept of preserving the residual space, defined in Appendix 1. The superstructure of the vehicle shall have the sufficient strength to ensure that the residual space during and after the rollover test on complete vehicle is uncompromised.
 - 7.3.1. Intrusion. No part of the vehicle located outside the residual space at the start of the test (e.g. wheelchair lifts, stanchions, safety rings, and luggage racks) shall intrude into the residual space during the test. Any structural parts, which are originally in the residual space (e.g. vertical handholds) shall be ignored when evaluating the intrusion into the residual space.
 - 7.3.2. Projection. No part of the residual space shall project outside the contour of the deformed structure. The contour of the deformed structure shall be determined sequentially, between every adjacent window and/or door pillar. The contour between two deformed pillars shall be established as a theoretical surface, determined by straight lines. It shall connect inside contour points of the pillars at the same elevation, above the floor level, before the rollover test.

8. DISCLAIMER

This specification is extracted from, and is consistent with bus safety standards as required by the referenced U.S., U.N., and E.U. regulations as of the date of release of this Revision.

Neither the Crashworthiness and Impact Analysis Laboratory of the FAMU-FSU College of Engineering, its faculty, Florida State University, Florida A&M University, and their respective Boards of Trustees, nor the Florida Department of Transportation make any warranty, express or implied, as to the accuracy, quality or usefulness of the information contained in this publication for any purpose. In no event shall FAMU-FSU College of Engineering, Florida State University,

Florida A & M University, their respective Boards of Trustees, nor the Florida Department of Transportation be liable for any direct, indirect, punitive, incidental, special, consequential damages, or any damages whatsoever arising out of or connected with the use or misuse of this document. The parties do not warrant that the prescribed tests and calculations are sufficient to establish the safety or structural integrity of any vehicle in an actual collision.

Appendix 1

RESIDUAL SPACE

An envelope of the vehicle's residual space is defined by creating a vertical transverse polynomial within the vehicle, which has an outline described in Figures A1.1 (a) and A1.1 (c), and moving it along the vehicle longitudinal center plane VLCP (see Figure A1.1(b)) as follows [1]:

1. The S_R point is located on the seat-back of each outer forward or rearward facing seat (or assumed seat position), 500 mm above the floor under the seat, 150 mm from the inside surface of the side wall. No account shall be made of wheel arches and other changes of the floor height. These dimensions shall also be applied in the case of inward facing seats in their center planes.
2. If the two sides of the vehicle are not symmetric within the floor arrangement and, therefore, the height of the S_R points are different, the step between the two floor lines of the residual space shall be taken as the vehicle longitudinal center plane (see Figure A1.1(c));
3. The rearmost position of the residual space is a vertical plane 200 mm behind the S_R point of the rearmost outer seat, or the inner face of the rear wall of the vehicle if this is less than 200 mm behind that S_R point.

The foremost position of the residual space is a vertical plane 600 mm in front of the S_R point of the foremost seat (whether passenger, crew, or driver) in the vehicle seat at its fully forward adjustment.

If the rearmost and foremost seats on the two sides of the vehicle are not in the same transverse planes, the length of the residual space on each side will be different;

4. The residual space is continuous in the passenger, crew and driver compartment(s) between its rearmost and foremost plane and is defined by moving the defined vertical transverse plane through the length of the vehicle along straight lines through the S_R points on both sides of the vehicle. Behind the rearmost and in front of the foremost seat S_R point the straight lines are horizontal (See Figure A1.1).
5. The manufacturer may define a larger residual space than is required for a given seat arrangement, to simulate a worst case in a group of vehicle types to allow for future design development.

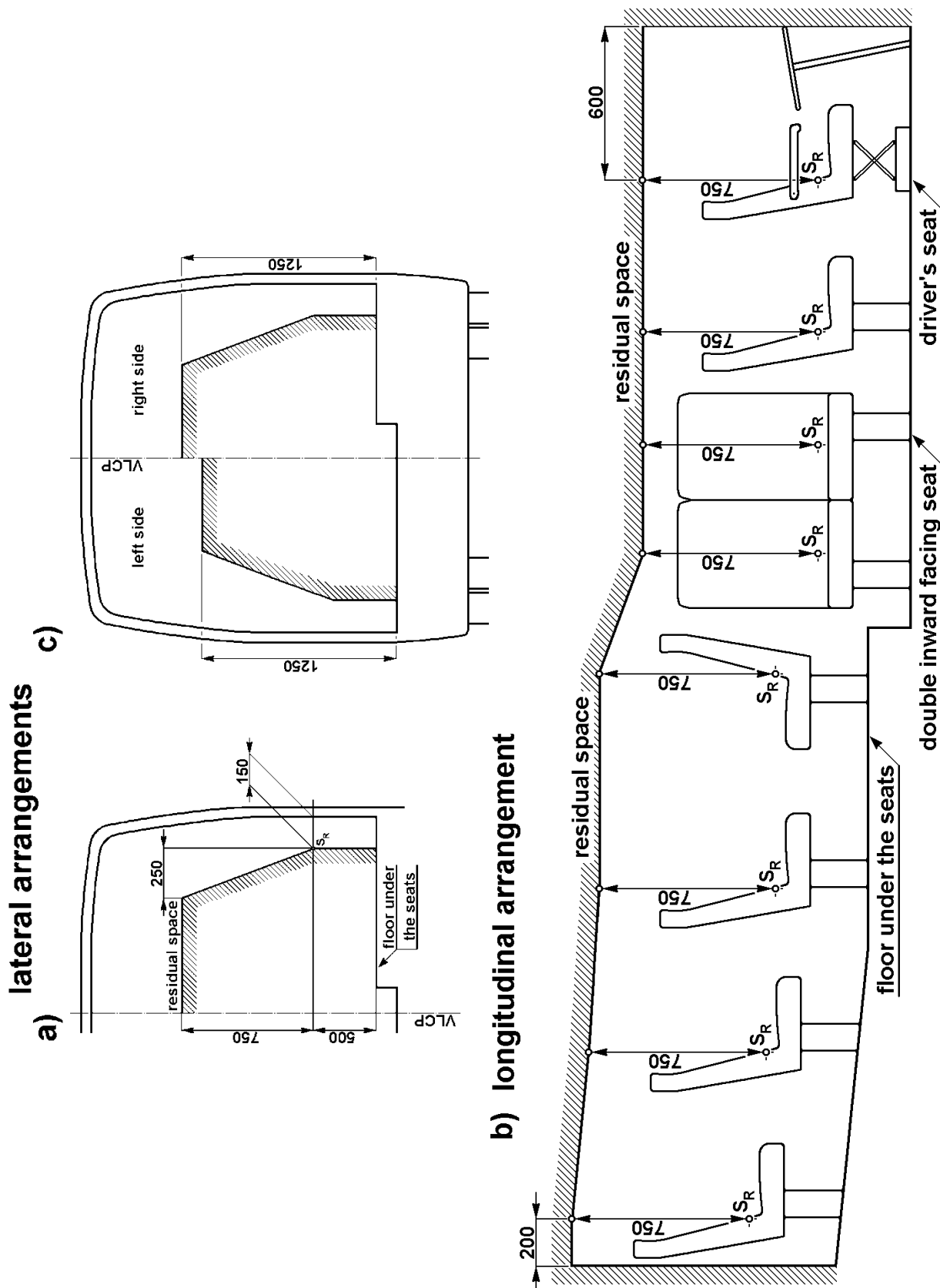
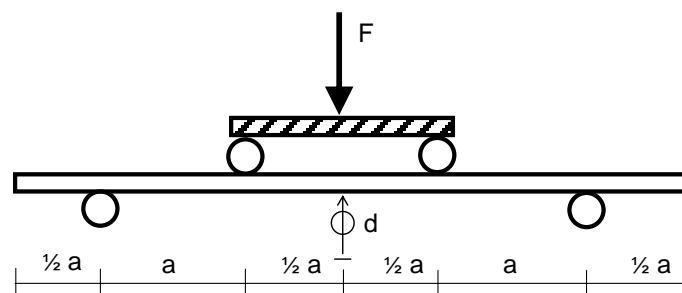

Figure A1.1 - Specification of the residual space [1],[3]

Appendix 2

MATERIAL TESTING OF MAJOR STRUCTURAL PARTS OF THE BUS BODY

1. At least three sets of specimens cut out of the original bus components such as: body skin (outer layer), tubes used as the cage elements, and floor panel shall be delivered by the manufacturer for material testing to determine properties of the materials used for the bus.
2. Samples cut out of the floor plate shall be tested for static four point bending. The rectangular specimens with the dimensions $4a \times 0.5a$, where 'a' is the characteristic dimension ranging from 4 to 12 in., shall be loaded according to Figure A2.1. The point load F and a corresponding displacement "d" at the mid-span of beam shall be recorded. The test shall be conducted until failure.

Figure A2.1 Test setup for four point bending with $a=1$ ft.

3. Material samples extracted from the body skin and from the structural elements shall undergo the tensile test. These coupons shall be of a rectangular shape with an aspect ratio (longer side to the smaller side) equal to ten. Precise dimensions must be determined based on the capabilities of the testing equipment.
4. Each test shall be repeated at least once under the same conditions as the original one.
5. The readings of instantaneous loading and corresponding strain or displacement shall be acquired simultaneously.
6. Values of recorded loading and strains will be used to determine stress-strain relations with engineering (nominal) values. They will be converted to real (actual) properties and will be used as an input in the F.E. model.
7. The main tensile testing shall be conducted as quasi-static with the loading rate smaller than the maximum specified in the appropriate standard for laboratory testing. The quasi-static tensile tests shall be repeated with the maximum allowed loading speed resulting in quasi-dynamic tests. The time for each reading shall be recorded in this case. This quasi-dynamic data can be used to estimate the strain rate dependence of the material tested.

Appendix 3

QUASI-STATIC TESTS OF ROOF-TO-WALL AND WALL-TO-FLOOR CONNECTIONS

1. Crashworthiness of the bus structure during a side impact or rollover accidents depends on its roof-to-wall and wall-to-floor connections. The test setup is presented in Figure A3.1. The width of the roof, floor and wall panels shall be the same and shall include at least two vertical elements of the steel frame and at least two horizontal steel elements (tubes or C-channels) in the floor. The wall panel shall be cut at the level just under the window. The roof and floor width shall be of approximately the same length.
2. The roof or floor panel shall be fixed while the wall panel is loaded horizontally inwards during the test. The loading shall be applied to the top edge of the wall section. The load shall be evenly distributed along the entire panel length through a rigid strip as presented in Figure A3.1.

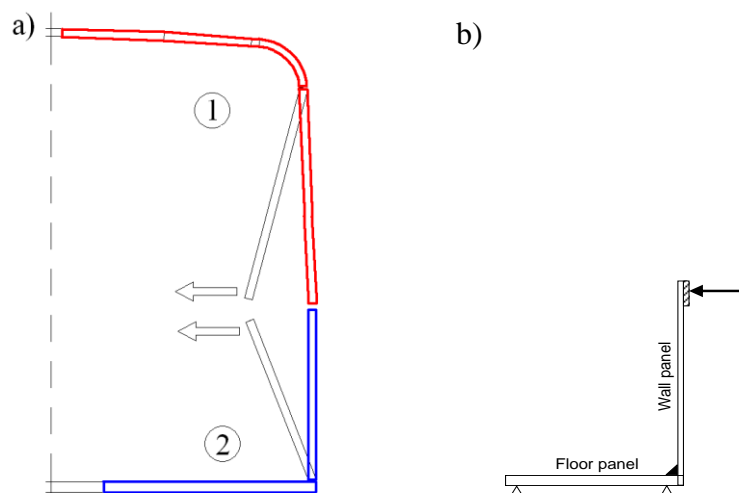

Figure A3.1 Setup for connection testing. a) Roof-to-wall and wall-to-floor connections, b) Supports and force application for the wall-to-floor connection.

3. Loading and the resulting displacement along its direction shall be recorded simultaneously during the test. The load shall be increased gradually, taking measurements of the associated deformation at discrete intervals until the ultimate deformation is reached. The resulting resistance function (force vs. displacement, or bending moment vs. angle of rotation) shall allow identifying plastic zones (PZ), as shown in Figure A3.2, [1]. The frequency of measurement shall allow producing a continuous curve. The "measured range", the range of deformation over which measurement has been made, shall include the phase of the plastic deformation and shall reach beyond the point of maximum loading. Both load and deformation shall be measured to an accuracy of ± 1 per cent.

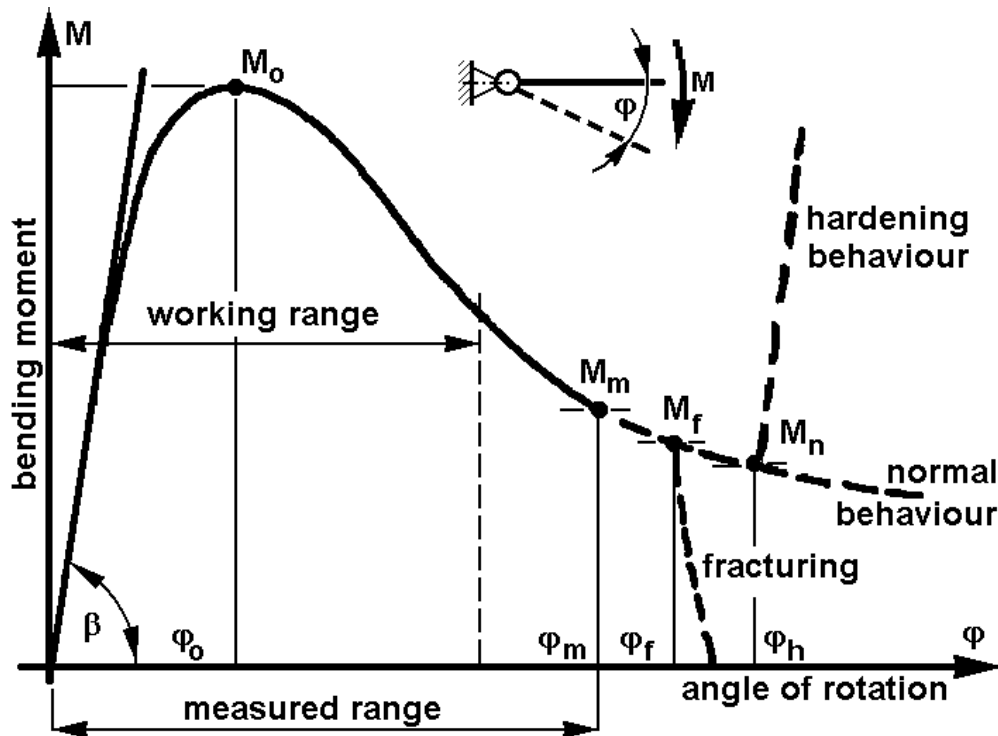

Figure A3.2 A sample of the resistance function with a plastic hinge, [1].

4. If the applied load changes its direction due to large deformations of the wall panel, the resulting plastic displacement and an angle at which the force is applied shall be recorded during the experiment.

Appendix 4

IMPACT HAMMER TEST OF A BUS SIDE WALL PANEL

1. Plastic zones PZ can be identified through either quasi-static or dynamic tests. The dynamic characteristics of a PZ may be determined in two ways:
 - by dynamic impact testing of the component.
 - by using a dynamic factor K_d to scale up the quasi-static PZ characteristics, as shown in Figure A4.1. In the second method, the values of the quasi-static bending moment may be magnified by K_d factor. Regulation 66 r. 01 allows using $K_d = 1.2$ factor for steel structural elements without laboratory test [1].

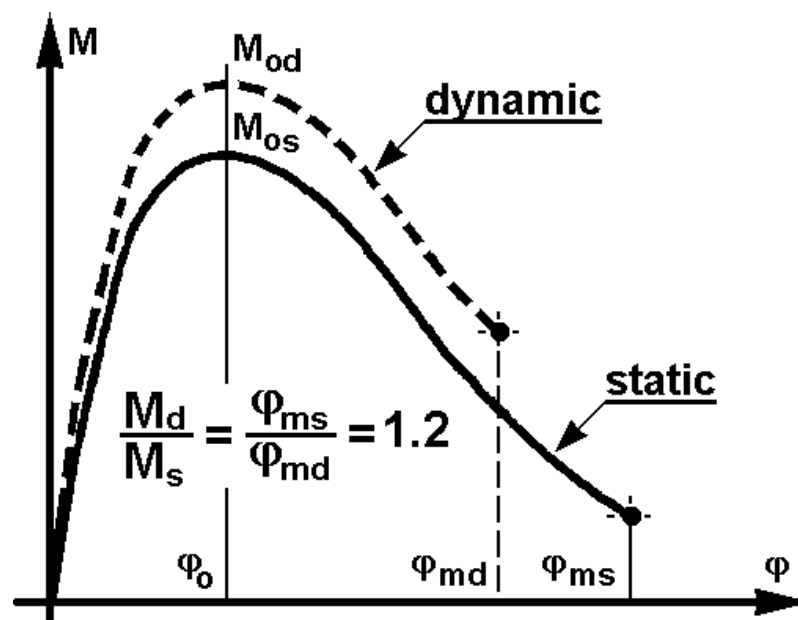

Figure A4.1 Plastic zone dynamic characteristics derived from static testing [1]

2. The major objective of experimental tests is to validate the assumed FE material models, material properties, and contact description for a bus wall panel in a simple dynamic impact test using the following verification procedure:
 - 2.1. Define and prepare a suitable section of the bus body a x b, Figure A4.2. A good cooperation with a producer is required in this stage to obtain a representative and adequate part of the bus body. The selected panel shall represent an actual part of the bus without any modifications, additional reinforcements, etc.
 - 2.2. Take measurements of the initial geometric configuration of the connection, in terms of its dimensions, connections between individual elements, thicknesses and other structural characteristics. Loading and boundary conditions shall be closely monitored (as specified in this Appendix) since any deviation may significantly alter the test result.

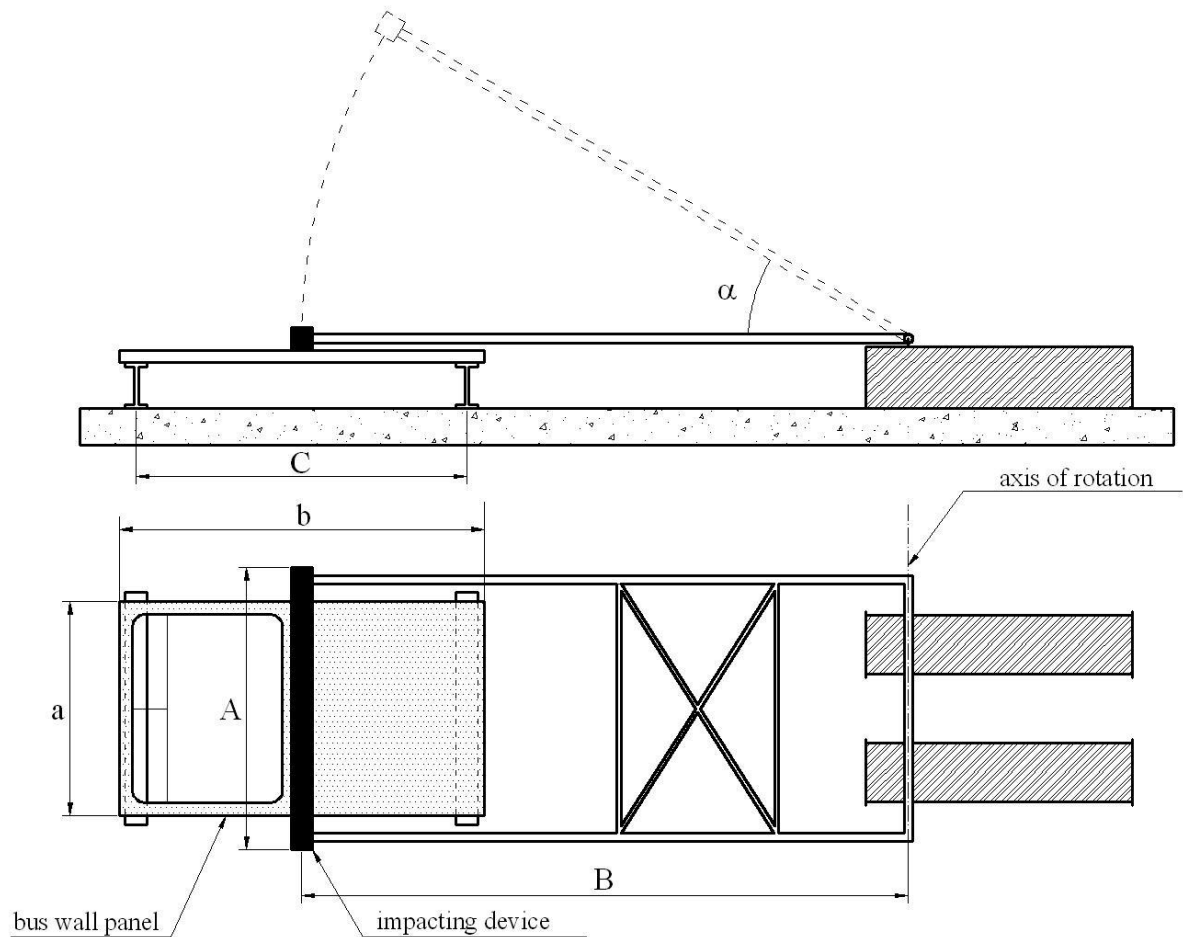

Figure A4.2 The impact test setup for bus wall panels, [2].

- 2.3. Estimate the required value of impacting mass. An underestimated impacting mass leads to small deflections and poor validation of the assumed nonlinear material models. Excessive deflections due to overestimated impacting mass are inconclusive for numerical simulation – the tested element is simply damaged, and no information about its behavior can be obtained.
- 2.4. Perform the impact test.
- 2.5. Measure permanent deflections, and note damages and characteristic features of the deformed sample.
- 2.6. Develop a numerical FE model of the test setup and perform a computational analysis of the test.
- 2.7. Compare the numerical and experimental results. Due to the short duration of the entire event, only the final displacements shall be compared. Data acquisition of time histories of strains, displacements, and accelerations for the points on the test sample is optional. It requires more instrumentation labor and expensive testing equipment, without significant gain in accuracy of the measured data.

- 2.8. Modify the original assumptions used for the numerical model. If necessary, the additional experimental tests shall be carried out.
3. Experimental setup. The experimental setup is built with welded steel elements, and placed on a flat, solid concrete surface. Due to heavy supporting elements, no additional fixing elements shall be used in order to prevent the lateral sliding of the supports during the impact. The test device, presented in Figure A4.2, consists of the following parts:
 - 3.1. An impacting frame, with necessary stiffeners. The impacting beam is $A=2,445$ mm (96”) long. Both arms are $B=3,020$ mm (119”) long. The impacting beam is hollow with adjustable mass. Its mass can be increased by filling it with water, or by adding solid weights on its top.
 - 3.2. A supporting structure, connecting the frame with heavy solid support.
 - 3.3. Supports for the test sample, at the distance C, Figure A4.2.
 - 3.4. A lifting device with a pulley and adequate release mechanism.

Appendix 5

CENTER OF GRAVITY OF THE VEHICLE

1. General principles

1.1. The total energy to be absorbed during a bus rollover directly depend on the location of the vehicle center of gravity (CG). Therefore, its determination shall be as accurate as possible. The method of measurement of dimensions, angles and load values, and the accuracy of measurement shall be recorded for assessment by a qualified technical service. The following accuracy of measuring is required [1]:

- | | | |
|---|-------------|---------------------|
| ○ for measurements smaller than 2,000 mm, | accuracy of | ± 1 mm |
| ○ for measurements greater than 2,000 mm, | accuracy of | ± 0.05 per cent |
| ○ for measured angles, | accuracy of | ± 1 per cent |
| ○ for measured load values | accuracy of | ± 0.2 per cent |

The wheel-base(s) and the distance between the centers of the footprint of the wheel(s) at each axle (the track of each axle) shall be determined from the manufacturer's drawings.

1.2. Blocked suspension is specified as the condition for determining centre of gravity and for carrying out the actual rollover test. The suspension shall be blocked in the normal operating position as defined by the manufacturer.

1.3. The position of the CG is defined by the following three parameters:

1.3.1. longitudinal distance (l_1) from the center line of front axle,

1.3.2. transverse distance (t) from the vertical longitudinal central plane of the vehicle,

1.3.3. vertical height (h_0) above the flat horizontal ground level when all tires are inflated as specified for the vehicle.

1.4. A method for determining l_1 , t , h_0 , using load cells is outlined below. Alternative methods using lifting equipment and/or tilt tables for example may be considered by the technical service which will decide if the method is acceptable based on its degree of accuracy (see paragraph 1.1. above).

1.5. The CG position of the unloaded vehicle (unloaded curb mass M_k) shall be determined by measurements, as follows.

2. Measurements

2.1. The longitudinal (l_1) and transverse (t) coordinates of CG shall be determined on a common horizontal ground (see Figure A5.1) where each wheel or twinned wheel of the vehicle is standing on an individual load cell. Each steered wheel shall be set to its straight-ahead position.

2.2. The individual load-cell readings shall be noted simultaneously and shall be used to calculate the total vehicle mass and the CG position.

- 2.3. The longitudinal position of the CG relative to the center of the contact point of the front wheels (see Figure A5.1) is given by:

$$l_1 = \frac{(P_3 + P_4) \cdot L_1 + (P_5 + P_6) \cdot L_2}{(P_{\text{total}})} \quad (\text{A5.1})$$

where:

P_1 = reaction load on the load cell under the left-hand wheel of the first axle

P_2 = reaction load on the load cell under the right-hand wheel of the first axle

P_3 = reaction load on the load cell under the left-hand wheel(s) of the second axle

P_4 = reaction load on the load cell under the right-hand wheel(s) of the second axle

P_5 = reaction load on the load cell under the left-hand wheel(s) of the third axle

P_6 = reaction load on the load cell under the right-hand wheel(s) of the third axle

$P_{\text{total}} = (P_1 + P_2 + P_3 + P_4 + P_5 + P_6) = M_k$ unloaded curb mass; or,

$= M_t$ total effective vehicle mass, as appropriate

L_1 = the distance from center of wheel on 1st axle to center of wheel on second axle

L_2 = the distance from center of wheel on 1st axle to center of wheel on third axle, if fitted

If the vehicle has only two axles, the terms associated with the third axle in equation (A5.1) and (A5.2) shall be dropped.

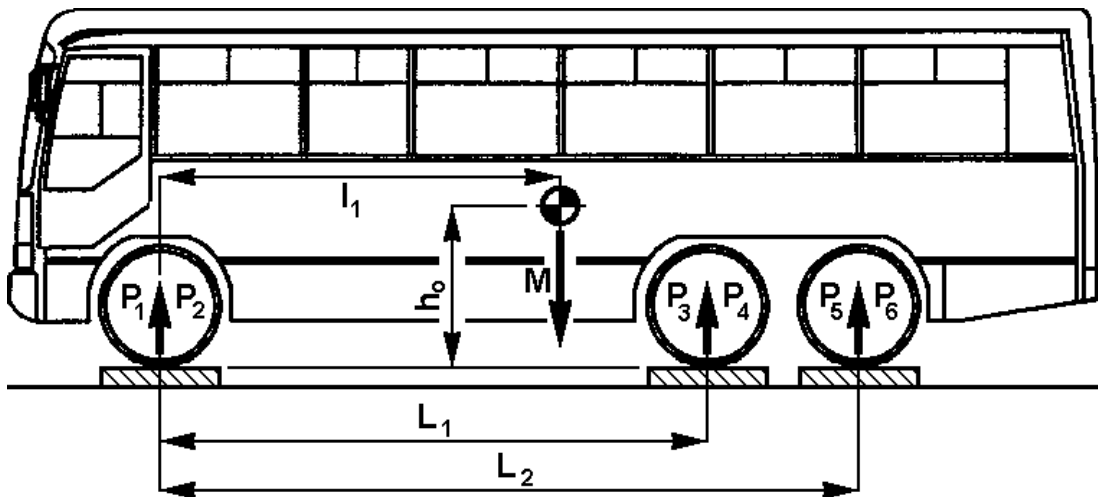

Figure A5.1 Longitudinal position of the CG, [1].

- 2.4. The transverse position (t) of the vehicle's the CG relative to its longitudinal vertical center plane (see Figure A5.2) is given by:

$$t = \left((P_1 - P_2) \frac{T_1}{2} + (P_3 - P_4) \frac{T_2}{2} + (P_5 - P_6) \frac{T_3}{2} \right) \cdot \frac{1}{P_{\text{total}}} \quad (\text{A5.2})$$

where:

- T_1 = distance between the centers of the footprint of the wheel(s) at each end of the first axle,
 T_2 = distance between the centers of the footprint of the wheel(s) at each end of the second axle,
 T_3 = distance between the centers of the footprint of the wheel(s) at each end of the third axle.

If the value of (t) is negative, then the CG of the vehicle is located to the right of the centerline of the vehicle.

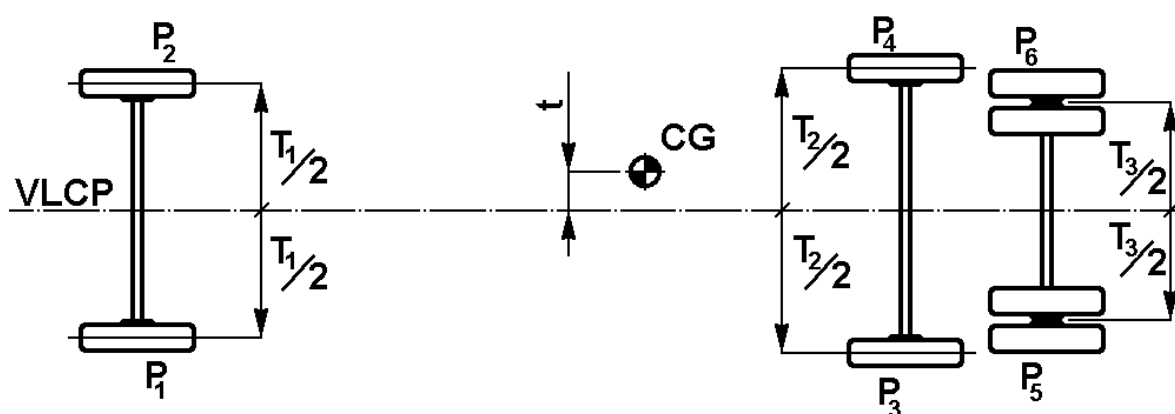

Figure A5.2 Transverse position of center of gravity, [1].

- 2.5. The vertical location of the CG (h_0) shall be determined by tilting the vehicle longitudinally and using individual load-cells at the wheels of two axles.
- 2.5.1. Two load-cells shall be positioned on a common horizontal plane, to accommodate the front wheels. The horizontal plane shall be at sufficient height above the surrounding surfaces that the vehicle can be tilted forward to the required angle (see section 2.5.2. below) without its nose touching that surface.
- 2.5.2. A second pair of load-cells shall be placed in a common horizontal plane on top of support structures to support the wheels of the second axle of the vehicle. The support structures shall be sufficiently tall to generate a significant tilt angle α ($> 20^\circ$) for the vehicle. An increased angle results in more accurate location of the CG – see Figure A5.3. The vehicle is repositioned on the four load-cells, with the front wheels blocked to prevent the vehicle from rolling forward. Each steered wheel shall be set to its straight-ahead steer position.
- 2.5.3. The individual load-cell readings shall be noted simultaneously and shall be used to check the total vehicle mass and its center of gravity position.
- 2.5.4. The tilt angle shall be determined by the Equation A5.3, (see also Figure A5.3):

$$\alpha = \sin^{-1}\left(\frac{H}{L_1}\right) \quad (\text{A5.3})$$

where:

H = height difference between the footprints of the wheels of the first and second axles

L_1 = the distance from the center of wheel first and second axles

2.5.5. The unloaded mass of the vehicle shall be checked as follows:

$$F_{\text{total}} = F_1 + F_2 + F_3 + F_4 \equiv P_{\text{total}} \equiv M_k \quad (\text{A5.4})$$

where:

F_1 = reaction load on the load cell under the left hand wheel of the first axle

F_2 = reaction load on the load cell under the right hand wheel of the first axle

F_3 = reaction load on the load cell under the left hand wheel of the second axle

F_4 = reaction load on the load cell under the right hand wheel of the second axle

If this equation is not satisfied, the measurement shall be repeated and/or the manufacturer shall be asked to modify the value of the unloaded curb mass in the technical description of the vehicle.

2.5.6. The height (h_o) of the vehicle CG is given by:

$$h_o = r + \left(\frac{1}{\tan \alpha} \right) \left(l_1 - L_1 \frac{F_3 + F_4}{P_{\text{total}}} \right) \quad (\text{A5.5})$$

where:

r = a vertical distance between the wheel center (on first axle) and the load cell top surface

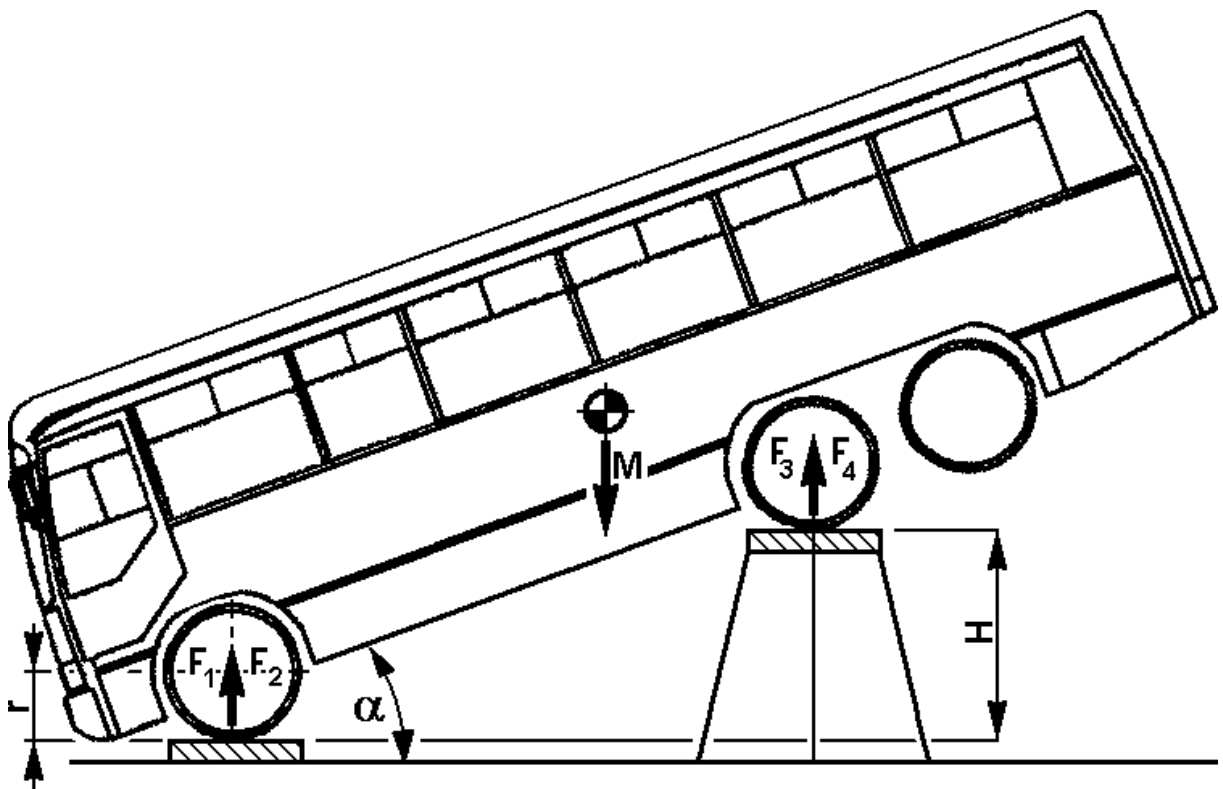

Figure A5.3 A test the vertical location of the CG, [1].

Appendix 6

SIDE IMPACT TEST

The side impact test provides information on the structural response of the passenger compartment and the resulting safety of the bus passengers.

1. An experimental test or a finite element analysis shall be used for a side impact assessment of a paratransit bus.
2. The bus shall be impacted by the Insurance Institute for Highway Safety movable barrier, as shown in Figure A6.1, [6], [7].
3. The impacted paratransit bus shall be stationary and positioned on a rigid, horizontal surface.
4. The impacting bogie shall have mass of 1.54 tons, a velocity of 30 mph, and an approach angle of 90°.
5. The impact zone shall be selected in such a way that the closest point of the impacting bumper shall be located at a distance of $d = 100$ mm from the closest point of the rear wheel of the bus, on the road (driver) side of the vehicle.
6. The test is judged as successful if the residual space (Appendix 1) of the bus is preserved.

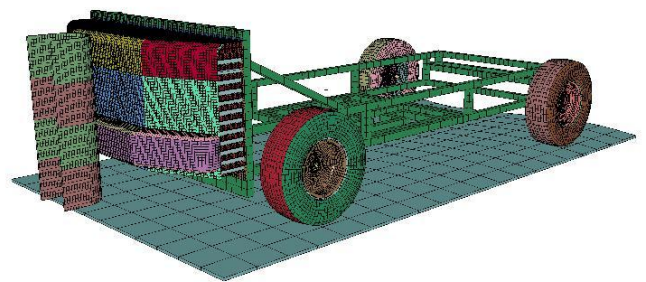

Figure A6.1 A movable barrier used by the Insurance Institute for Highway Safety for side impact tests. Left: an actual IIHS bogie with aluminum honeycomb head
(Source: <http://www.saturnfans.com/photos/showphoto.php/photo/44595/size/blog.php>).
Right: a public domain finite element model.

Appendix 7

ROLL-OVER TEST

The rollover test of a complete vehicle shall be performed on a tilt table (see Figure A7.1), as follows:

1. The complete vehicle is placed on a tilt table, with blocked suspension and is tilted slowly with its CG moving to its unstable equilibrium position CG' , as shown in Figure A7.1. If the vehicle type is not fitted with occupant restraints it will be tested at unloaded curb mass. If the vehicle type is fitted with occupant restraints it will be tested at total effective vehicle mass;
2. The rollover test starts in this unstable vehicle position (CG') with zero angular velocity and with the axis of rotation running through the wheel-ground contact points. At this moment the vehicle is characterized by reference energy E_R (CG' , see Figure A7.1).
3. The vehicle tips over into a ditch, having a horizontal, dry and smooth concrete ground surface with a nominal depth of 800 mm;
4. The detailed technical specification of the rollover test on a complete vehicle as the basic approval test is provided in [1].

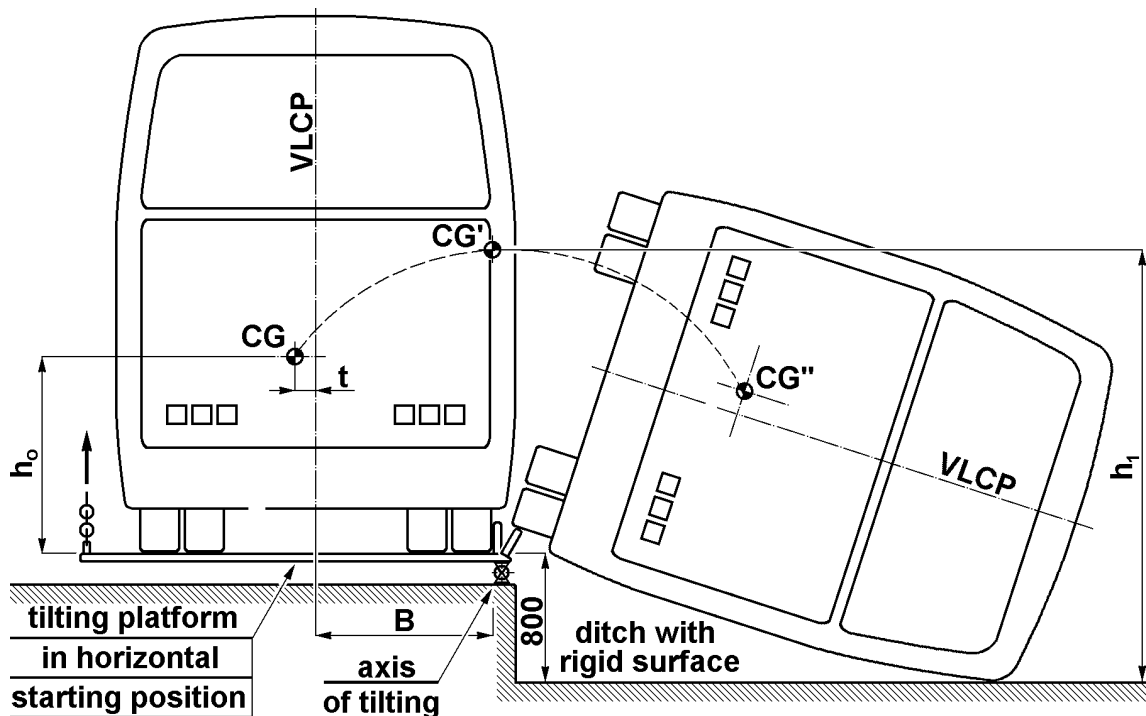

Figure A7.1 Specification of the rollover test on a complete vehicle showing the path of the center of gravity from the initial CG point, through the unstable equilibrium CG' , until the crashed position CG'' , when the cantrail touches the ground[1].

Appendix 8

PRE-APPROVAL

A complete crashworthiness and safety assessment process, as described in this document, is very detailed and long. The following sub-set of faster, experimental tests (as shown in Figure 1) is required to predict if the paratransit bus is likely to pass the complete assessment process:

- a. Material testing of major structural parts of the bus body (Appendix 2)
 - b. Quasi-static tests of roof-to-wall and wall-to-floor connections (Appendix 3), and
 - c. Impact hammer test of a bus side wall panel (Appendix 4).
1. Positive results of these tests shall be required to request a pre-approval status.
 2. A full crashworthiness and safety assessment process for the paratransit bus shall be completed within a year from the time of the initial pre-approval to secure the approval status.

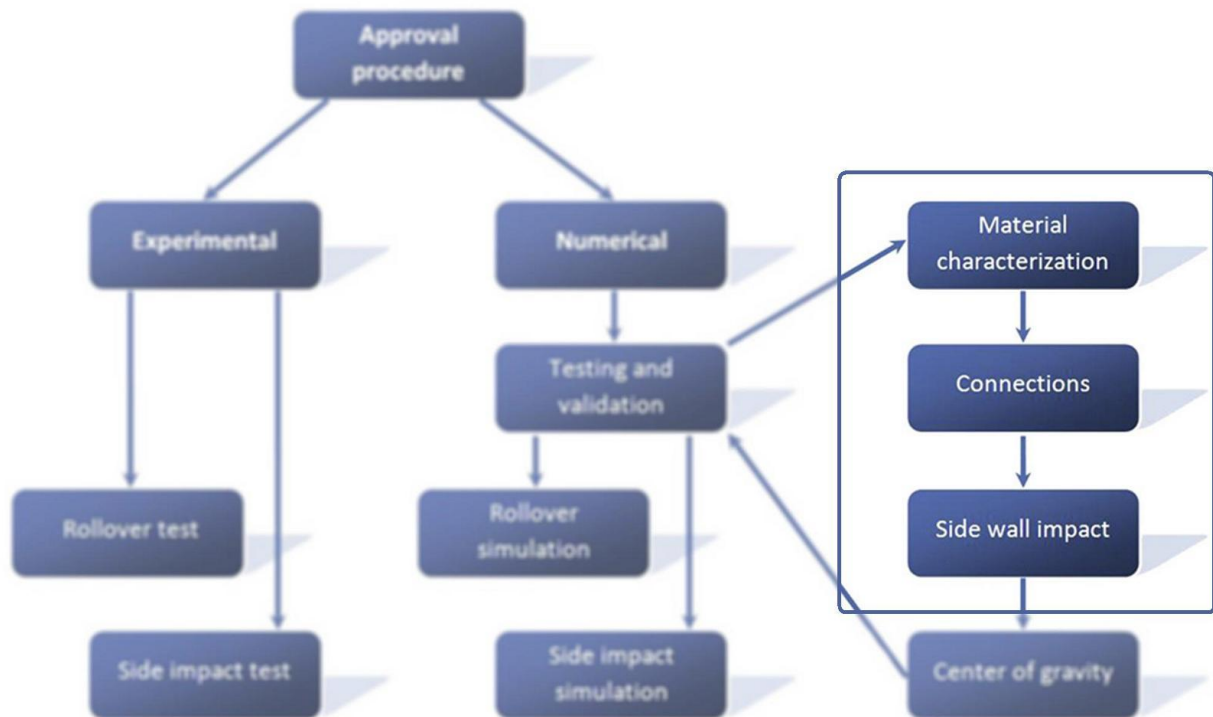

REFERENCES

- [1] United Nations Economic Commission for Europe Regulation 66, Addendum 65, *Uniform technical prescriptions concerning the approval of large passenger vehicles with regard to the strength of their superstructure* Feb, 22, 2006 <http://www.unece.org/trans/main/wp29/wp29regs/r066r1e.pdf>
- [2] Official Journal of the European Communities *Directive 2001/85/EC relating to special provisions for vehicles used for the carriage of passengers comprising more than eight seats in addition to the driver's seat*, November, 2001
<http://eur-lex.europa.eu/LexUriServ/LexUriServ.do?uri=CELEX:32001L0085:EN:NOT>
- [3] Christopher Green, *Bus body structural integrity analysis*, final report. Michigan Department of Transportation, December 1998.
- [4] United Nations Economic Commission for Europe Regulation 66 *Strength of the superstructure of large passenger vehicles*
<http://www.unece.org/trans/main/wp29/wp29regs61-80.html>
- [5] United Nations Economic Commission for Europe Regulation 107 *Double-deck large passenger vehicles* <http://www.unece.org/trans/main/wp29/wp29regs101-120.html>
- [6] Insurance Institute for Highway Safety, *Side Impact Crashworthiness Evaluation. Crash Test Protocol (Version V)*, May 2008 (last visited: October 2009).
http://www.iihs.org/ratings/protocols/pdf/test_protocol_side.pdf
- [7] Insurance Institute for Highway Safety, *Side Impact Crashworthiness Evaluation. Moving Deformable Barrier Specifications*, October 2007 (last visited: October 2009).
http://www.iihs.org/ratings/protocols/pdf/side_barrier_spec.pdf